

VKR DN 10÷50

DUAL BLOCK® regulating ball valve



VKR DN 10÷50

The VKR DUAL BLOCK® valve combines high reliability and safety aspects typical of VKD full bore ball valves with the new flow adjustment function with typical linear curve that meets the most stringent needs typical of industrial applications.



DUAL BLOCK® REGULATING BALL VALVE

- Connection system for weld, threaded and flanged joints
- Patented **SEAT STOP®** ball seat carrier system that lets you micro-adjust ball seats and minimise axial force effects
- Easy radial disassembly allowing quick replacement of O-rings and ball seats without any need for tools
- **PN10 True Union valve body** made for PP-H injection moulding equipped with built-in bores for actuation. ISO 9393 compliant test requisites
- Option of disassembling downstream pipes with the valve in the closed position
- High surface finish stem with double O-Ring and double groove ball connection
- **Integrated bracket** for valve anchoring
- Ball seat carrier can be adjusted using the **Easytorque adjustment kit**
- Actuation option: version with electric modulating actuator with 4-20 mA / 0-10 V inlet and 4-20 mA / 0-10 V outlet to monitor the position
- Valve suitable for carrying fluids that are clean and free of suspended particles

Technical specifications	
Construction	2-way True Union regulating ball valve with locked carrier and lockable union nuts
Size range	DN 10 ÷ 50
Nominal pressure	PN 10 con acqua a 20 °C
Temperature range	0 °C ÷ 95 °C
Coupling standards	Welding: EN ISO 15494 Can be coupled to pipes according to EN ISO 15494 Thread: ISO 228-1, EN 10226-1/2 Flanging system: ISO 7005-1, EN ISO 1092-1, EN ISO 15494, EN 558-1, ANSI B.16.5 cl. 150
Reference standards	Construction criteria: EN ISO 16135, EN ISO 15494 Test methods and requirements: ISO 9393 Installation criteria: DVS 2202-1, DVS 2207-11, DVS 2208-1, UNI 11318 Actuator couplings: ISO 5211
Valve material	PP-H
Seal material	EPDM, FKM (standard size O-Rings); PTFE (ball seats)
Control options	Manual control; electric actuator

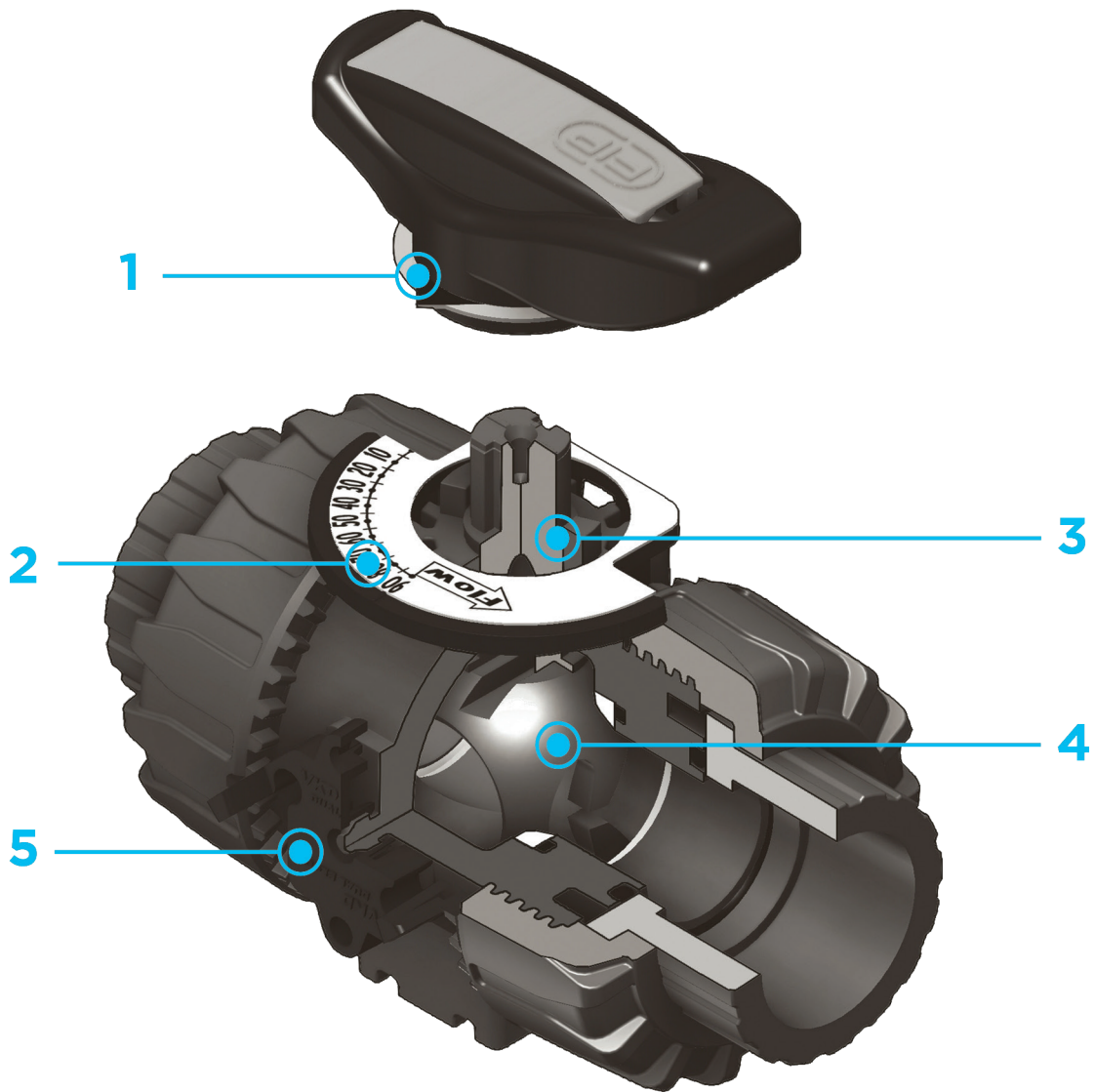

1 HIPVC ergonomic multifunctional handle with **position indicator** and tool to adjust the ball seat carrier

2 Flow direction and opening angle indication plate with **graduated scale with 5° detail** for clear and accurate readings

3 90° operating angle that permits **the use of standard** quarter turn **actuators**

4 The patented ball design provides **linear flow adjustment** throughout its range of operation even when the valve is open just a few

degrees.

5 Patented **DUAL BLOCK®** system: prevents union nuts from loosening even under extreme operating conditions: e.g. vibration or thermal expansion

TECHNICAL DATA

PRESSURE VARIATION ACCORDING TO TEMPERATURE

Graph valid for water and harmless fluids to which the material is classified as CHEMICALLY RESISTANT. In other cases, a reduction of the nominal PN pressure is required (25 years with safety factor).

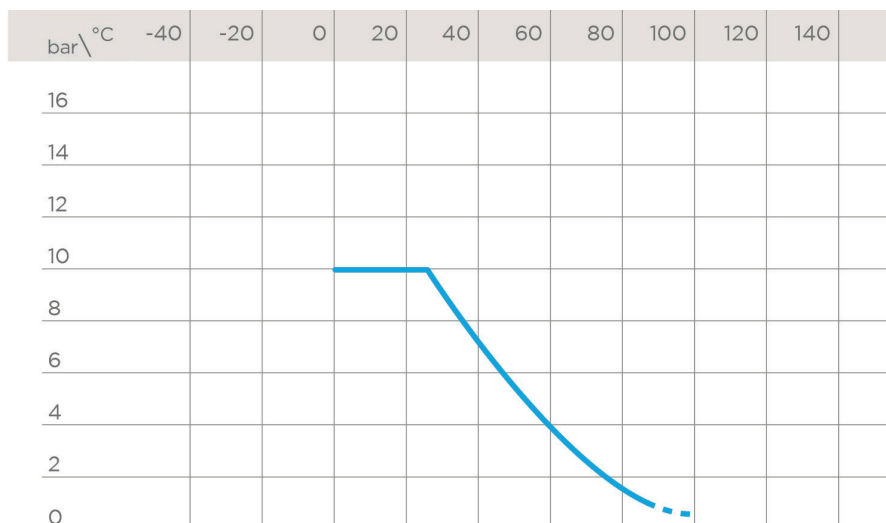

PRESSURE DROP GRAPH

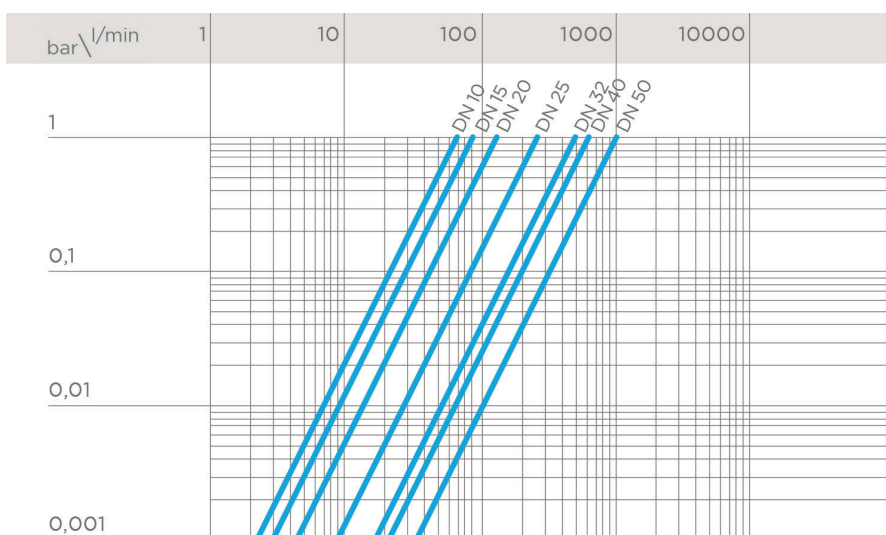

K_v100 FLOW COEFFICIENT

The K_v100 flow coefficient is the Q flow rate of litres per minute of water at a temperature of 20°C that will generate Δp= 1 bar pressure drop at a certain valve position. The Kv100 values shown in the table are calculated with the valve completely open.

DN	10	15	20	25	32	40	50
Kv100 l/min	83	88	135	256	478	592	1068

RELATIVE FLOW COEFFICIENT DIAGRAM

The relative flow coefficient is the flow rate through the valve as a function of the degree of valve aperture.

Horizontal axis: Ball aperture angle
Vertical axis: Relative flow coefficient

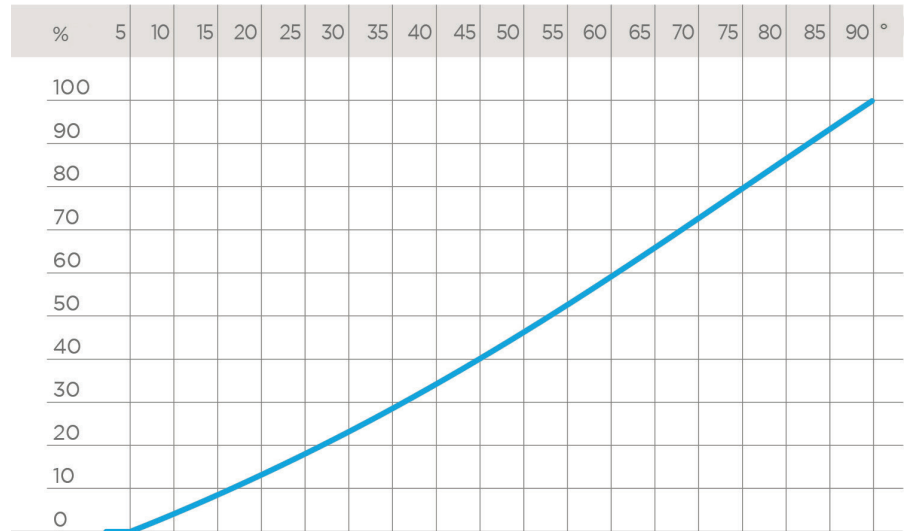

OPERATING TORQUE AT MAXIMUM WORKING PRESSURE

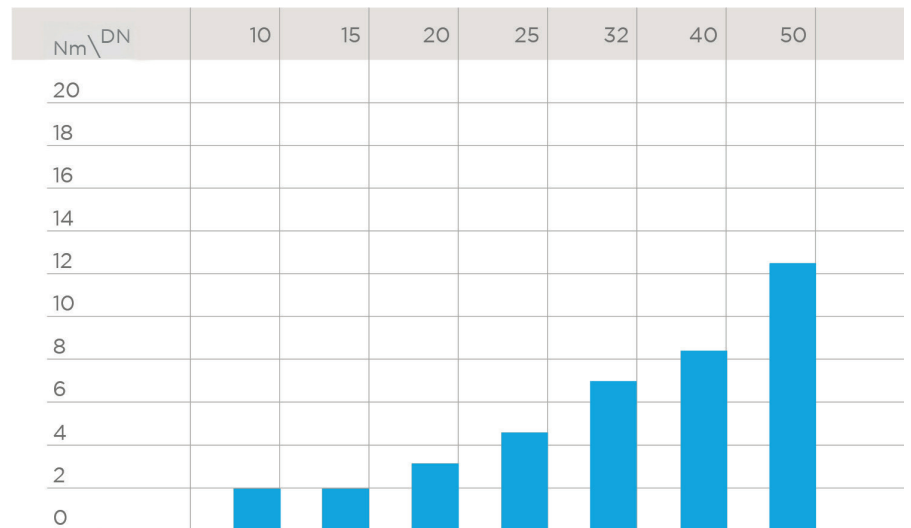

DIMENSIONS

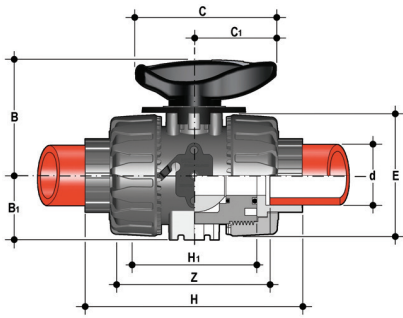

VKRIM

DUAL BLOCK® regulating ball valve with female ends for socket welding, metric series

d	DN	PN	B	B ₁	C	C ₁	E	H	H ₁	Z	g	EPDM code	FKM code
16	10	10	54	29	67	40	54	102	65	74,5	150	VKRIM016E	VKRIM016F
20	15	10	54	29	67	40	54	102	65	73	145	VKRIM020E	VKRIM020F
25	20	10	65	34,5	85	49	65	114	70	82	218	VKRIM025E	VKRIM025F
32	25	10	69,5	39	85	49	73	126	78	90	298	VKRIM032E	VKRIM032F
40	32	10	82,5	46	108	64	86	141	88	100	480	VKRIM040E	VKRIM040F
50	40	10	89	52	108	64	98	164	93	117	682	VKRIM050E	VKRIM050F
63	50	10	108	62	134	76	122	199	111	144	1166	VKRIM063E	VKRIM063F

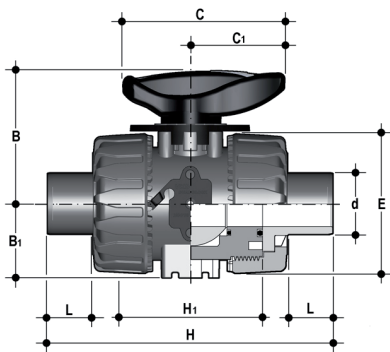

VKRDM

DUAL BLOCK® regulating ball valve with male ends for socket welding, metric series

d	DN	PN	B	B ₁	C	C ₁	E	H	H ₁	L	g	EPDM code	FKM code
20	15	10	54	29	67	40	54	144	70	18	222	VKRDM020E	VKRDM020F
25	20	10	65	34,5	85	49	65	154	78	20	303	VKRDM025E	VKRDM025F
32	25	10	69,5	39	85	49	73	174	88	22	485	VKRDM032E	VKRDM032F
40	32	10	82,5	46	108	64	86	194	93	23	672	VKRDM040E	VKRDM040F
50	40	10	89	52	108	64	98	224	111	29	1176	VKRDM050E	VKRDM050F
63	50	10	108	62	134	76	122	224	111	38	1607	VKRDM063E	VKRDM063F

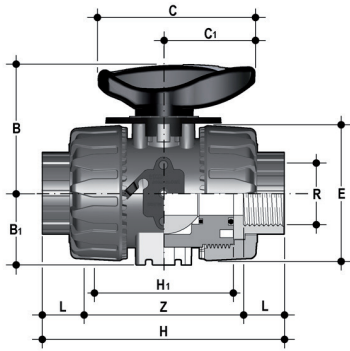

VKRFM

DUAL BLOCK® regulating ball valve with BSP threaded female ends

R	DN	PN	B	B ₁	C	C ₁	E	H	H ₁	L	Z	g	EPDM code	FKM code
3/8"	10	10	54	29	67	40	54	103	65	15	80	145	VKRFM038E	VKRFM038F
1/2"	15	10	54	29	67	40	54	110	65	16	83	220	VKRFM012E	VKRFM012F
3/4"	20	10	65	34,5	85	49	65	116	70	19	96	298	VKRFM034E	VKRFM034F
1"	25	10	69,5	39	85	49	73	134	78	21	110	488	VKRFM100E	VKRFM100F
1" 1/4	32	10	82,5	46	108	64	86	153	88	21	113	682	VKRFM114E	VKRFM114F
1" 1/2	40	10	89	52	108	64	98	156	93	26	135	1161	VKRFM112E	VKRFM112F
2"	50	10	108	62	134	76	122	186	111	26	135	1667	VKRFM200E	VKRFM200F

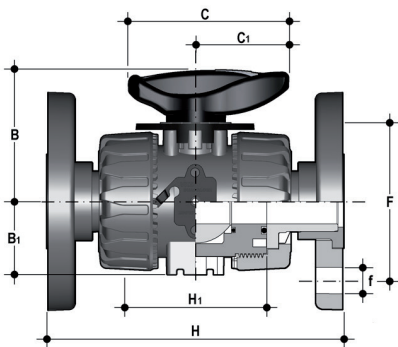

VKROM

DUAL BLOCK® regulating ball valve with EN/ISO/DIN fixed flange, drilled PN10/16. Face to face according to EN 558-1

d	DN	PN	B	B ₁	C	C ₁	F	f	H	H ₁	U	Sp	g	EPDM code	FKM code
20	15	10	54	29	67	40	65	14	130	65	4	11	387	VKROM020E	VKROM020F
25	20	10	65	34,5	85	49	75	14	150	70	4	14	504	VKROM025E	VKROM025F
32	25	10	69,5	39	85	49	85	14	160	78	4	14	697	VKROM032E	VKROM032F
40	32	10	82,5	46	108	64	100	18	180	88	4	14	1075	VKROM040E	VKROM040F
50	40	10	89	52	108	64	110	18	200	93	4	16	1346	VKROM050E	VKROM050F
63	50	10	108	62	134	76	125	18	230	111	4	16	2060	VKROM063E	VKROM063F

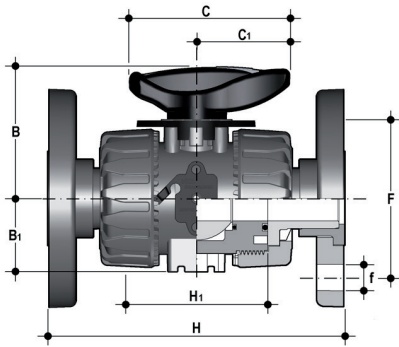

VKROAM

DUAL BLOCK® regulating ball valve with ANSI B16.5 cl.150 #FF fixed flange bore

d	DN	PN	B	B ₁	C	C ₁	F	f	H	H ₁	Sp	U	g	EPDM code	FKM code
1/2"	15	10	54	29	67	40	60,3	15,9	143	65	11	4	387	VKROAM012E	VKROAM012F
3/4"	20	10	65	34,5	85	49	69,9	15,9	172	70	14	4	504	VKROAM034E	VKROAM034F
1"	25	10	69,5	39	85	49	79,4	15,9	187	78	14	4	697	VKROAM100E	VKROAM100F
1" 1/4	32	10	82,5	46	108	64	88,9	15,9	190	88	14	4	1075	VKROAM114E	VKROAM114F
1" 1/2	40	10	89	52	108	64	98,4	15,9	212	93	16	4	1346	VKROAM112E	VKROAM112F
2"	50	10	108	62	134	76	120,7	19,1	234	111	16	4	2060	VKROAM200E	VKROAM200F

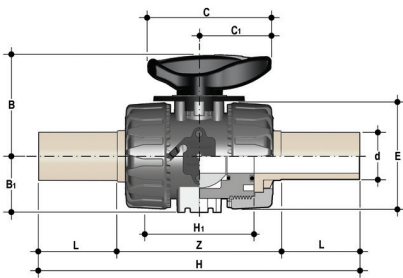

VKRBM

DUAL BLOCK® regulating ball valve with long spigot male ends in PP-H for butt welding or electrofusion (CVDM)

d	DN	PN	B	B ₁	C	C ₁	E	H	H ₁	L	Z	g	EPDM code	FKM code
20	15	10	54	29	67	40	54	175	65	40,5	94	220	VKRBM020E	VKRBM020F
25	20	10	65	35	85	49	65	212	70	54	106	340	VKRBM025E	VKRBM025F
32	25	10	70	39	85	49	73	226	78	56	117	443	VKRBM032E	VKRBM032F
40	32	10	83	46	108	64	86	246	88	56	131	593	VKRBM040E	VKRBM040F
50	40	10	89	52	108	64	98	271	93	60,5	145	945	VKRBM050E	VKRBM050F
63	50	10	108	62	134	76	122	300	111	65,5	161	1607	VKRBM063E	VKRBM063F

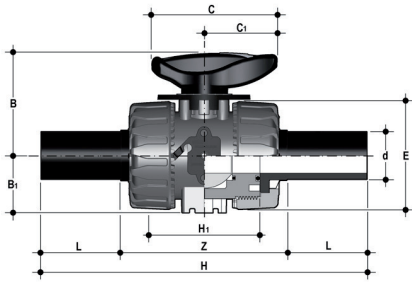

VKRBEM

Dual Block® regulating ball valve with PE100 SDR 11 male end connectors for butt welding or electrofusion (CVDE)

d	DN	PN	B	B ₁	C	C ₁	E	H	H ₁	L	Z	g	EPDM code	FKM code
20	15	10	54	29	67	40	54	175	65	40,5	94	210	VKRBEM020E	VKRBEM020F
25	20	10	65	34,5	85	49	65	213	70	54	106	325	VKRBEM025E	VKRBEM025F
32	25	10	69,5	39	85	49	73	228	78	56	117	420	VKRBEM032E	VKRBEM032F
40	32	10	82,5	46	108	64	86	247	88	56	131	570	VKRBEM040E	VKRBEM040F
50	40	10	89	52	108	64	98	271	93	60,5	145	900	VKRBEM050E	VKRBEM050F
63	50	10	108	62	134	76	122	300	111	65,5	161	1500	VKRBEM063E	VKRBEM063F

ACCESSORI

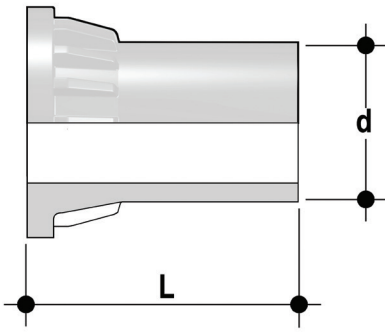

CVDM

End connectors in PP-H SDR 11 PN 10, long spigot, for butt welding

d	DN	PN	L	SDR	Code
20	15	10	55	11	CVDM11020
25	20	10	70	11	CVDM11025
32	25	10	74	11	CVDM11032
40	32	10	78	11	CVDM11040
50	40	10	84	11	CVDM11050
63	50	10	91	11	CVDM11063

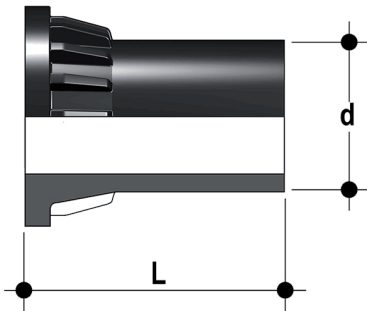

CVDE

Long spigot PE100 end connectors for joints with electrofusion fittings or for butt welding

d	DN	PN	L	SDR	Code
20	15	16	55	11	CVDE11020
25	20	16	70	11	CVDE11025
32	25	16	74	11	CVDE11032
40	32	16	78	11	CVDE11040
50	40	16	84	11	CVDE11050
63	50	16	91	11	CVDE11063

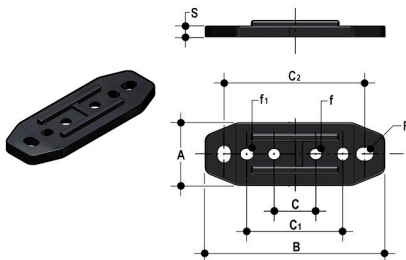

PMKD

Wall mounting plate

d	DN	A	B	C	C ₁	C ₂	F	f	f ₁	S	Code
16	10	30	86	20	46	67,5	6,5	5,3	5,5	5	PMKD1
20	15	30	86	20	46	67,5	6,5	5,3	5,5	5	PMKD1
25	20	30	86	20	46	67,5	6,5	5,3	5,5	5	PMKD1
32	25	30	86	20	46	67,5	6,5	5,3	5,5	5	PMKD1
40	32	40	122	30	72	102	6,5	6,3	6,5	6	PMKD2
50	40	40	122	30	72	102	6,5	6,3	6,5	6	PMKD2
63	50	40	122	30	72	102	6,5	6,3	6,5	6	PMKD2



Easytorque Kit

Kit for ball seat carrier tightening adjustment for DUAL BLOCK® DN 10+50 series valves

d	DN	Tightening torque recommended*	Code
3/8"-1/2"	10-15	3 N m - 2,21 Lbf ft	KET01
3/4"	20	4 N m - 2,95 Lbf ft	KET01
1"	25	5 N m - 3,69 Lbf ft	KET01
1" 1/4	32	5 N m - 3,69 Lbf ft	KET01
1" 1/2	40	7 N m - 5,16 Lbf ft	KET01
2"	50	9 N m - 6,64 Lbf ft	KET01

*calculated in ideal installation conditions

FASTENING AND SUPPORTING

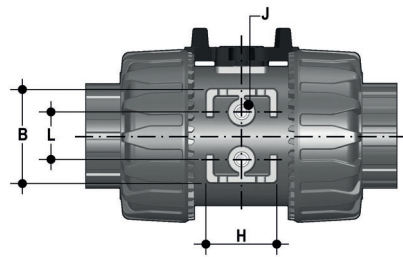

All valves, whether manual or driven, must be adequately supported in many applications.

The VKR valve series is therefore ready to be equipped with threaded supporting brackets (optional) that permits direct anchoring of the valve body without the need of other components.

For wall installation, dedicated PMKD mounting plates which are available as accessories can be used. These plates should be fastened to the valve before wall installation.

PMKD plates also allow VKR valve alignment with FIP ZIKM pipe clips as well as allowing different sizes of valves to be aligned.

d	DN	g	H	L	J*
16	10	31,5	27	20	M4 x 6
20	15	31,5	27	20	M4 x 6
25	20	40	30	20	M4 x 6
32	25	40	30	20	M4 x 6
40	32	50	35	30	M6 x 10
50	40	50	35	30	M6 x 10
63	50	60	40	30	M6 x 10

* With threaded inserts

COMPONENTS

EXPLODED VIEW

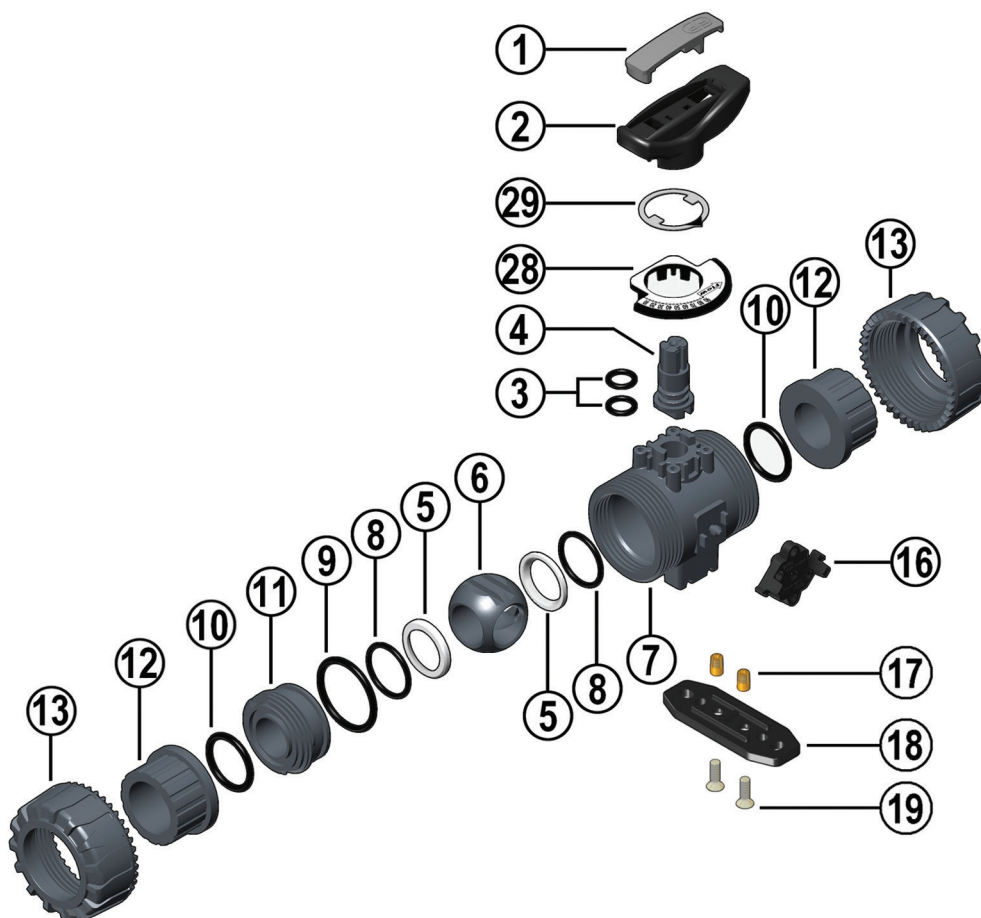

- | | | | | | |
|----------|---------------------------------|-----------|---------------------------------------|-----------|---|
| 1 | Handle insert (PVC - 1) | 8 | Ball seat O-Rings (EPDM or FKM - 2)* | 13 | Union nut (PP-H - 2) |
| 2 | Handle (HIPVC - 1) | 9 | Radial seal O-Ring (EPDM or FKM - 1)* | 16 | DUAL BLOCK® (POM - 1) |
| 3 | Stem O-ring (EPDM or FKM - 2)* | 10 | Socket seal O-Ring (EPDM or FKM - 2)* | 17 | Threaded inserts (STAINLESS steel or Brass - 2)** |
| 4 | Stem (PP-H - 1) | 11 | Ball seat carrier (PP-H - 1) | 18 | Distance plate (PP-GR - 1)** |
| 5 | Ball seat (PTFE - 2)* | 12 | End connector (PP-H - 2)* | 19 | Screw (STAINLESS steel - 2)** |
| 6 | Patented ball design (PP-H - 1) | | | 28 | Graduated plate (POM-PVC - 1) |
| 7 | Body (PP-H - 1) | | | 29 | Indicator (PVC - 1) |

* Spare parts

** Accessories

The component material and quantity supplied are indicated in the parentheses.

DISASSEMBLY

- 1) Isolate the valve from the line (release the pressure and empty the pipeline).
- 2) Unlock the union nuts by pressing the lever on the DUAL BLOCK® (16) along the axis and separate it from the union nut (fig. 1). It is also possible to completely remove the block device from the body of the valve.
- 3) Fully unscrew the union nuts (13) and extract the body sideways.
- 4) Before dismounting, hold the valve in a vertical position and open it 45° to drain any liquid that might remain.
- 5) After closing the valve, remove the special insert (1) from the handle (2) and push the two projecting ends into the corresponding recesses on the ball seat carrier (11). Rotate the stop ring anti-clockwise to extract it.
- 6) Pull the handle (2) upwards to remove it from the valve stem (4).
- 7) Make sure that the position indicator (29) remains properly fastened to the handle (2).
- 8) Press on the ball from the side opposite the "REGULAR - ADJUST" label, being sure not to scratch it, until the ball seat carrier exits (11), then extract the ball (6).
- 9) Press the stem (4) inwards until it exits the valve body.
- 10) All the O-rings (3, 8, 9, 10) and PTFE ball seats (5) must be removed from their grooves, as shown in the exploded view.

ASSEMBLY

- 1) All the O-rings (3, 8, 9, 10) must be inserted in their grooves as shown in the exploded view.
- 2) Insert the stem (4) from inside the body (7).
- 3) Place the PTFE ball seats (5) in the housings in the body (7) and in the ball seat carrier (11).
- 4) Insert the ball (6) in the body as shown in Fig. 3
- 5) Screw the carrier (11) into the body and tighten up in the clockwise direction using the special insert (1) to limit stop.
- 6) Position the indicator (29) on the handle with the pointer set to 0 on the graduated scale while making sure that the valve is in the closed position (fig. 2-3).
- 7) Insert the handle (2) with the insert (1) in its housing on the stem (4).
- 8) Insert the valve between the end connectors (12) making sure that they match the direction of flow shown on the plate (fig. 2) then tighten the union nuts (13) making sure that the socket seal O-rings (10) do not come out of their grooves.



Note: during assembly operations, it is advisable to lubricate the rubber seals. Mineral oils are not recommended for this task as they react aggressively with EPDM rubber.

Fig. 1



Fig. 2



Fig. 3

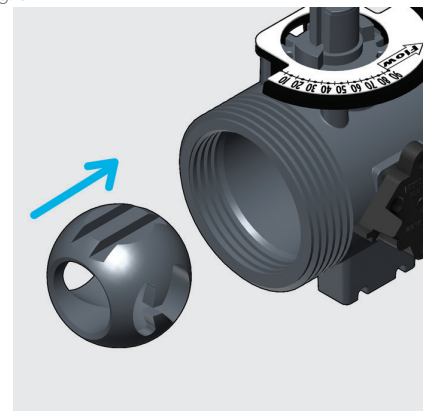

Fig. 4



INSTALLATION

Before proceeding with installation, please follow these instructions carefully:

- 1) Check that the pipes to be connected to the valve are aligned in order to avoid mechanical stress on the threaded joints.
 - 2) Check that the DUAL BLOCK® union nut locking device (16) is fitted to the valve body.
 - 3) To release the union nuts (13), axially press the release lever to separate the lock and then unscrew it in the counter-clockwise direction.
 - 4) Unscrew the union nuts (13) and insert them on the pipe segments.
 - 5) Solvent weld or screw the end connectors (12) onto the pipe ends.
 - 6) Position the valve between the pipe end connectors making sure the that direction of flow is the same as shown on the plate (Fig.4). Hand tighten the union nuts in the clockwise direction. Do not use a wrench or other tools which might damage the surface.
 - 7) Lock the union nuts by returning the DUAL BLOCK® to its housing, pressing on it until the hinges lock on the nuts.
 - 8) If necessary, support the pipework with FIP pipe clips or by means of the carrier built into the valve itself (see paragraph "fastening and supporting").
- Seals can be adjusted using the removable insert on the handle.
The seals can be installed later with the valve installed on the pipe by simply tightening the union nuts. This "micro adjustment", only possible with FIP valves thanks to the patented "Seat stop system", allows the seal to be recovered where PTFE ball seats are worn due to a high number of operations.
The Easytorque kit can also be used for micro adjustments (fig. 5).

Fig.5



WARNINGS

Always avoid sudden closing operations and protect the valve from accidental operations.

