

FLUXO[®]



Heating, Cooling, and Water Supply System

1.6 FLUXO



PEX-Al-PEX Multi Layer Pipe
Brass Press Fittings



FLUXO[®] is a Fully-Compliant System



Heating



Supply



Hot and cold water



Drinking water

FLUXO[®] Smart System to Save Time



1- Cutting the pipe



2- Chamfering the pipe



3- Placing the fitting



4- Pressing the fitting

Perfect connections in record time: 3 times faster compared to traditional systems

Creating a system using traditional materials and welding techniques requires some time. As professional installer, you know exactly what we are talking about. Thanks to the FLUXO[®] multilayer system, your systems will be installed three times faster, regardless of the type of application and working procedures. Modern and simple, this system combines the benefits of hi-tech multilayer pipes with specifically-developed brass fittings. With a few operations: cutting the pipe, chamfering, inserting the fitting and pressing, and the connection is finished with the utmost ease and at top speed! With each connection you do, you will save precious minutes. But these minutes will turn into hours if you consider all the sites you work in. In a nutshell, this is the aim of the FLUXO[®] system: making your job easy and more profitable.

BEAR IN MIND, YOU CAN:

- Improve productivity on the job
- Reduce installation costs
- Avoid delays in delivery times

Compare costs and benefits.

FLUXO[®] will convince you from all points of view

If you compare the ensured benefits of the FLUXO[®] system with the costs of traditional installation techniques (labour time for welding, waste, slowness,

etc.) you will definitely notice a significant difference in the cost of the system. All this, without taking into consideration the cost fluctuations of metal (copper) and the irregular supply on construction sites and warehouses.

The time has come, therefore, to choose the FLUXO[®] multilayer system. The best way to actually see all the benefits of this system is to try it yourself. Ask your local dealer.

TIME

Connection with traditional technique



TIME

Connection with FLUXO[®] system



Take a Closer Look at FLUXO It Bends to Every Need



TECHNICAL FEATURES

FLUXO® multilayer pipe is easy to work with as it is flexible but, above all, it will firmly maintain the shape you give it. This is due to its composition: a pipe consisting of 5 layers which comes from the union between synthetic materials (PEX) and an inner layer of laser butt-welded aluminium. FLUXO® embraces the features of synthetic materials and metal materials, offering unparalleled benefits:

- **Simple installation** It is flexible, lightweight and free from "elastic memory", the FLUXO® pipe is the best solution for any water-supply system.
- **Absolute hygiene** It is suitable for drinking water and all food fluids, as certified by important external labor "Studi di Pisa".
- **Corrosion resistance** The polyethylene internal and external layers and the fittings provided with a dielectric barrier protect the aluminium against any type of chemical, electromagnetic and natural corrosion.
- **Low load losses** The internal polyethylene surface has a surface finish that can ensure significant reductions in load losses compared to classic metal pipes; furthermore, the absence of lime deposits or other scaling ensures a flow rate that remains constant over time.
- **Oxygen and light barrier** The aluminium layer blocks the passage of oxygen, water vapour and any other gas, therefore avoiding the formation of corrosion in the circuits. Aluminium is also a fully-effective barrier against UV radiation.
- **Reduced thermal expansion** Linear expansion caused by temperature variations is metal pipes. This ensures great stability as regards the size of the pipe and it is therefore subject to limited thermal stress.

Create any type of installation variants with safe and suitable fittings: use FLUXO® fittings

Our attention to quality and performance is clear from all FLUXO® system components, especially in the range of fittings. The size precision of FLUXO® fittings is absolute. The positioning of the O-rings on fittings is designed to obtain the maximum adherence between the fitting nipple and the internal layer of the pipe, ensuring long-lasting sealing performance.

Your fittings will therefore be created with extreme precision and safety.

The size of our product range is also another benefit: you can create any type of installation thanks to the variety of FLUXO® fittings.

As regards pipes, the range of fittings is available for diameters between 16 mm and 63 mm. The fittings are made from brass bars of the highest quality, ensuring optimum corrosion-resistant properties.

QUALITY AND RELIABILITY

Thanks to the best technology of composite materials and the continuous improvements, you can benefit from the extreme reliability of the multilayer FLUXO® system. Crosslinked polyethylene is abrasion resistant so it means the Fluxo pipes are durable 8 times lower than the plastic pipe and can be compared to.



Technical benefits

All the benefits of metal:

- rigidity and resistance
- low linear expansion
- versatility
- high professional quality



All the benefits of plastic materials:

- corrosion resistance
- light weight (products and equipment)
- simple and fast installation

It is perfectly compatible with most of the pressing machines on the market.

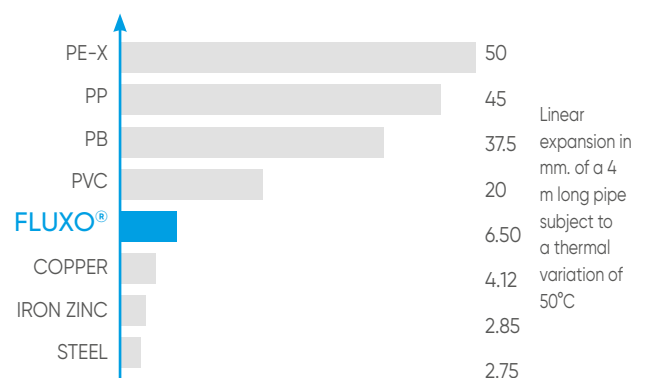

Made in Italy

The multilayer FLUXO® system is made in Italy according to the EN ISO 21003 standard. The EN ISO 21003 is the European standard providing the suitability features for the application of multilayer piping systems for hot and cold water supply inside buildings and for heating purposes.

- **Safety and reliability:** the FLUXO® system is the most advanced and professional solution for hot and cold water supply:
- **Compliance with Standards:** the FLUXO® pipes and fittings are manufactured in full compliance with regulations and prescriptions in terms of quality, hygiene and energy saving.
- **Safety:** the risk of fire on the construction site is practically eliminated, also avoiding unpleasant accidents such as burns on carpets, parquet or walls.
- **Reliability and durability:** the FLUXO® system, in addition to our ten-year warranty, is certified to last longer than 50 years.
- **Soundproofing:** the FLUXO® system significantly absorbs the vibrations and water-hammer effects which piping systems are subject to.

Application fields

Domestic water and heating

The top benefit of FLUXO® is its versatility. Regardless of the size of your construction site or the type of intervention, whether you are working in a single house or a block of flats, you will be able to install hot and cold water supply systems and heating systems with one only system.

Cooling

FLUXO® is also perfect for cooling systems which use cold water, thanks to the dedicated "POLAR" range of pipes which are specifically insulated with a particular high-density sheath characterised by a high thermal insulation coefficient.

Hygiene and drinking water

The system complies with the most important norm requirements in terms of hygiene and potability.

System certifications

The FLUXO® system has been tested and certified by significant certifying bodies such as: KIWA (Netherlands) and KQ (France) valid for the range included in the Avis Technique 14/15-1828 in compliance with the UNI EN ISO 21003 Standard ensuring duration, reliability and safety.



Kiwa certificate
System certification in accordance with the UNI EN ISO 21003 standard for the entire FLUXO range: pipe and press fittings. (Certificate no. K55985/03)



Cstb certification
System certification which states the durability and suitability for the installation of heating and domestic hot and cold water supply systems. Valid for the range included in the Avis Technique 14/13 - 1828.



Health compliance
FLUXO® has the important certification on French health compliance (ACS).

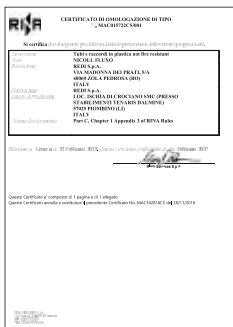

Rina certification
This certificate states the conformity and suitability of the FLUXO® multilayer pipe for use in the naval sector. (Certificate no. MAC015722CS/001)



DNV certification
Products approved by this certificate are accepted for installation on all vessels classed by DNV. (Certificate no. TAK000028U)

Design and installation

Calculation of the load losses

In general, the load losses which may occur on a water circuit can be divided in:

- 1 - Continuous load losses (YC)
- 2 - Localised load losses (YL)

The total load loss (Ytot) is the sum of these two types of losses and is measured in mwc (metres of water column). Therefore: **Ytot = YC + YL**

Continuous load losses (YC) are caused by the friction between the fluid and the internal surface of the pipe.

The multilayer FLUXO® pipe, in this case, shows one of its most significant benefits: its **low internal roughness** leads to very low continuous load losses with respect to traditional metal pipes.

The continuous load losses are calculated using the following formula: **YC = Ycu x pipe L**

Where:

- YC** = continuous load losses (mwc)
- Ycu** = unitary continuous load losses (mwc/m)
- pipe L** = length of the pipe (m)

The Ycu are the continuous load losses per metre of length and can be calculated on the basis of the flow capacity indicated in the table below.

Load loss diagram - ΔL (MBAR/M)

Flow capacity - Water temperature 50°

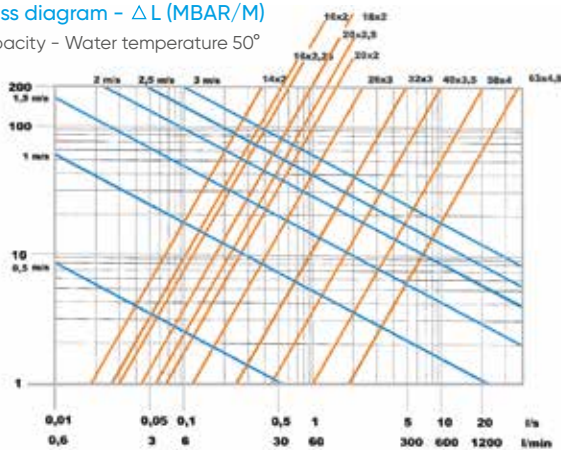

Load losses

Localised load losses (YL) are caused by the geometric variations of the system such as curves, elbows, valves, T-shaped fittings etc... The multilayer FLUXO® pipe offers significant benefits compared to traditional systems: the possibility of creating curves with a very small bending radius, reduces the installation of curves and elbows and therefore the load losses. Compared to PEX pipes, in addition, the presence of the aluminium layer ensures geometric stability and the circularity of the section minimising geometric variations and therefore the load losses. The geometry of the FLUXO® fittings is also designed to improve flow and therefore to reduce these types of load losses.

Localised load losses are calculated using the following formula: **YL = Ycu x eqL**

Where:

- YL** = localised load losses (mwc)
- Ycu** = unitary continuous load losses (mwc/m)
- eqL** = equivalent length of the pipe (m)

The equivalent lengths (eqL) depend on the type of the considered geometric discontinuity and are indicated in the figure below.

Fittings load loss

Discontinuity	Ø 14	Ø 16	Ø 18	Ø 20	Ø 26	Ø 32	Ø 40	Ø 50	Ø 63
Curve	0.7	0.6	0.55	0.5	0.4	0.3	0.3	0.2	0.2
Elbow Angle 45°	1.5	1.4	1.2	1.1	1.0	0.8	0.7	0.6	0.6
T	1.3	1.2	0.9	0.6	0.5	0.3	0.2	0.1	0.1
T	1.6	1.5	1.4	1.3	1.2	1.0	0.9	0.8	0.8
T	1.7	1.6	1.5	1.4	1.3	1.1	1.0	0.9	0.9
T	1.7	1.6	1.5	1.4	1.3	1.1	1.0	0.9	0.9
Straight fitting	1.0	0.9	0.7	0.5	0.4	0.3	0.2	0.1	0.1
Fittings for taps	1.4	1.3	1.2	1.1	/	/	/	/	/

Expansion calculation

The FLUXO® pipe has a thermal expansion similar to that of metal piping, thanks to the aluminium layer and to the adhesive which imposes the metal layer level of expansion on the PE-X layers. The table below shows the comparison between the thermal expansion coefficients of our pipe and that of other materials. The calculation formula for the thermal expansion of the pipe is the following: **L1 = α x L2 x T**

Where:

- L1** = Pipe expansion in mm
- L2** = Length of the pipe in m
- α** = Expansion coefficient of the material in mm/m°K
- T** = Difference between the service temperature and the temperature at the time of installation, expressed in °C

You can also calculate the pipe expansion by using the diagram on the side. By taking into consideration the horizontal axis which indicates the difference between the service temperature and that calculated at the time of installation, and intersecting the line on the diagram, you can read the expansion value (in mm) per metre of pipe on the vertical axis. To calculate the effective expansion, the latter value must be multiplied by the length of the pipe (expressed in m).

Thermal expansion coefficient of different materials

Type of piping	Expan. Coeff. α [mm/(m°k)]
FLUXO®	0.026
Galvanised steel	0.012
Stainless steel	0.017
Copper	0.017
Plastic material (PE-X PEHD PPRC)	0.19 - 0.20

Design recommendations

In order to maintain the expected performances and durability of this product range but, above all, to achieve a complete warranty coverage of the system, we recommend that you strictly follow the system design, installation and commissioning standards in order to make sure you carry out your work in a fully-professional manner.

Calculation of the length of the expansion bend

The length of the expansion bend can be deduced from the diagram below, or it can be calculated using the following formula: $b = K \times (D \times L)^{1/2}$

Where:

b = Bend length (in mm)

D = External diameter of the multilayer pipe (in mm)

L = Pipe expansion (calculated as shown above)

K = material constant (for the FLUXO® pipe = 33)

Example:

Calculation of an expansion bend

Calculation of the length of the expansion bend of a multilayer Fluxo pipe with $\varnothing 26$, 8 m long subject to a temperature variation of $T = 60^\circ\text{C}$

$$L1 = \alpha \times L2 \times T =$$

$$0.026 \times 8 \times 60 = 12.5 \text{ mm}$$

$$b = 33 \times (26 \times 12.5)^{1/2} = 595 \text{ mm}$$

Thermal expansion diagram

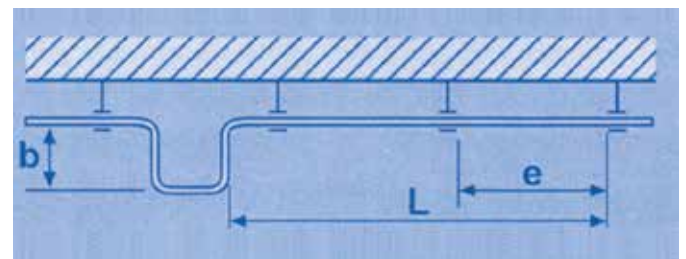
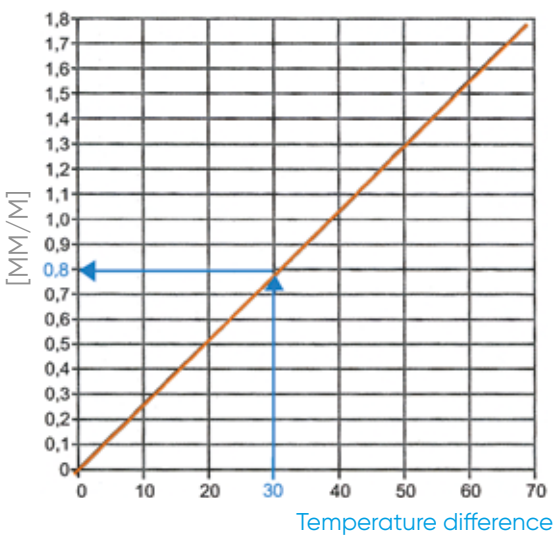

Expansion length ΔL (mm)

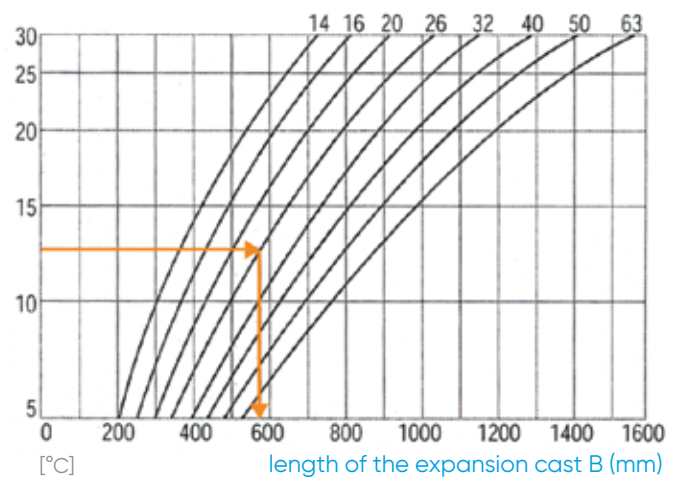

Expansion compensation

Even if the multilayer pipe has low expansion properties, heating and cooling can certainly induce the pipe to expand and contract. A compensation technique for free piping inside shafts, entails creating omega-shaped bends in the straight sections. If the piping is constrained or inside a wall, you can solve the problem by insulating the pipe.

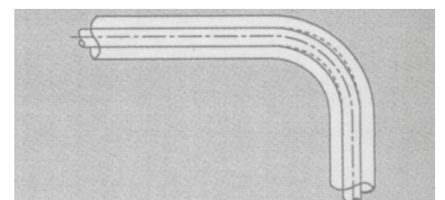
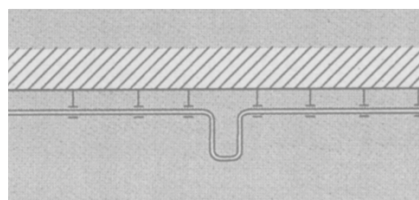
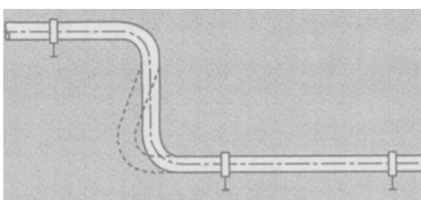

Pipe bending

One of the most significant benefits of the FLUXO[®] system is the ease with which it can be bent. This important result was only possible thanks to laser technology which ensures highly-resistant welds even with modest thicknesses. In this way we can also ensure an easy bending and geometric stability, in addition to the significant mechanical features of the pipe.

The methods of pipe bending are:

- manual bending
- bending using pipe-bending clamps

The table below shows the minimum obtainable values of bending radii.

External diameter (mm)	Ø14	Ø16	Ø18	Ø20	Ø26	Ø32	Ø40	Ø50	Ø63
Manual bending radius (mm)	70	80	90	100	110	160	550	700	---
Bending radius with bending clamp (mm)	35	45	55	60	95	125	180	210	315

Manual bending

For pipes with a modest diameter and for wide bending radii, manual bending is the fastest and most effective method: the installer must check that the pipe shows no signs of crushing signs on the surface which may be caused by improper bending techniques.

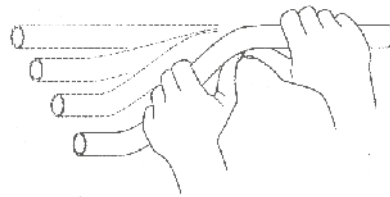

Bending using bending clamps

For smaller bending radii and/or for pipes with a larger diameter, we recommend that you use a bending clamp as shown below.



Phase 1 - Mark the middle of the bending curve.



Phase 2 - Place the pipe inside the bending clamp.

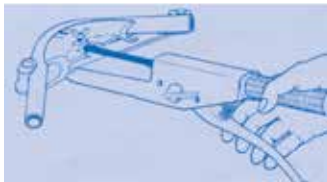

Phase 3 - Use the lever of the clamp until you reach the desired bending angle.



Phase 4 - Loosen the clamp to release the pipe.



Cutting and calibration

1- Cutting the pipe

Cut the pipe perpendicularly to its axis.



2- Inserting the fitting

Insert the fitting in the pipe until it reaches its stop (the O-rings must not be lubricated).



3- Calibrating the pipe

Calibrate and deburr the pipe, making sure you fully remove any plastic shavings.

Press Fittings Installation

Joints with press fittings

For mechanical connections with press fittings, after cutting the pipe perpendicularly to the pipe axis, and after calibration and deburring, insert the pipe into the fitting until it reaches its stop which can be accessible for inspection thanks to the openings and proceed with the pressing of the stainless steel sleeve by using the special tool as shown below.

Preparing the pressing machine

Note: use the appropriate clamp on the base for each size of fitting. Check that these measurements correspond with every application. Preparing the tool: remove the safety pin; insert the jaw; insert the safety pin fully.



1- Remove the safety pin



2- Insert the jaw



3- Insert the safety pin completely



Pressing the fitting

4- Positioning

Warning: place the fitting in the jaw correctly; the seal ring is provided with a design feature which "obliges" this positioning.



5- Pressing

Press the lever until the pressing clamp stops automatically.



6- Opening

Opening the jaw.

Rules for correct installation



Below you will find a set of instructions for the installation of the FLUXO® system to ensure its perfect operation and long lasting performance.

Coupling the fittings

The coupling of fittings in the FLUXO® system, male or female, with fittings of other brands and/or systems, complying with the UNI EN 10226 standard, does not require the use of additional sealing materials such as teflon, hemp, etc. The "construction" of the thread ensures the sealing of the coupling.

Pressing the fittings

The pressing must be carried out with the system completely installed in all its parts and without unnecessary stress which may compromise its correct operation over time.

Bending the pipes

To bend the pipes correctly, without creating dangerous stresses, you must measure and mark the pipe accurately and bend it manually or using bending clamps. Pressing must only be done after the pipe has been correctly installed, as shown in the figures below.

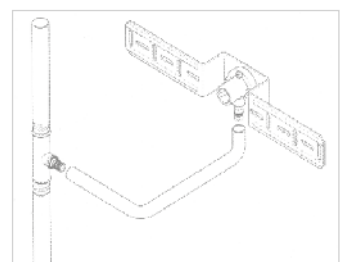
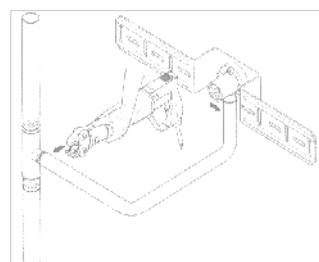
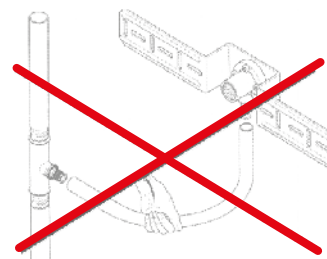

Installing "T" shaped fittings

To install "T" shaped fittings, install the pipe, secure it and then press the fittings as shown in the figure on the side.

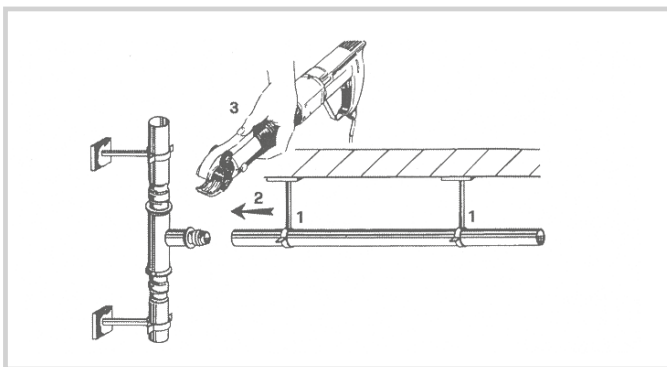
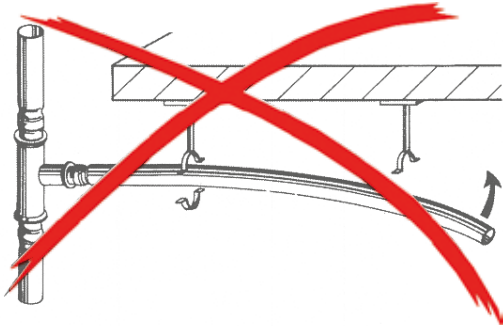

Securing the pipes

Pipes are to be secured using soundproof collars. If the collars are not soundproof, the pipes must be secured on the external insulation of the pipes.

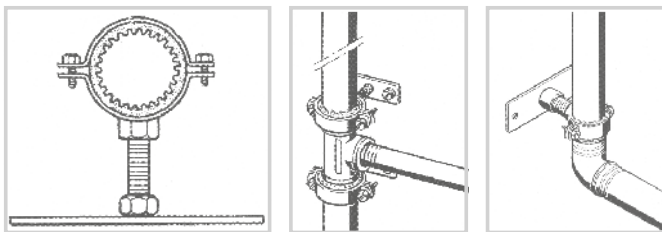

Distance between securing points

Correct positioning of the securing collars ensures correct pipe stability, without creating dangerous stress. The distances between the securing collars, according to the diameter of the pipes, are listed below. Pipes installed horizontally must be secured every 75 cm maximum. A securing collar must be installed 25 cm before and after each curve.

Diameter	Distance L
14 - 16	M
18 - 20	1
26	1.2
32	1.5

Testing Protocol

Testing the system

WARNING

Every system must be tested in accordance with the reference standard before concealing the system into the wall. Failing to perform this test will relieve the company of any liability arising from possible accidents, involving injury to persons or damage to property.

Civil liability regarding systems always lies with the installation company which must safeguard its work and perform tests on the systems as a standard requirement for the completion of the job.

The following is the correct procedure for testing in accordance with the DIN 1988 standards.

Pre-test. Duration 30 min.

Fill the system with fluid and bleed any air out of it via the top parts of the pipe system; then, apply a pressure of 15 bar for 15 minutes and check for any leaks in the mechanical fittings. The maximum pressure drop within the 30 minutes of the test is 0.3 bar.

Test. Duration 2 hours

After the pre-test and after having restored the pressure, proceed with the definitive test which requires longer verification times.

Apply once again a pressure of 15 bar to the system for a minimum of two hours within which the maximum pressure drops must not exceed 0.3 bar. After the positive outcome of the test you can conceal the system inside the wall.

Testing protocol

We recommend you always draft a report of the test stating its positive outcome. For such tests we recommend you use a pump fitted with a pressure gauge with 0.1 bar precision and connect it to the lowest point of the system to be tested. The concealing of the system must always be performed with the circuits under fixed service pressure.

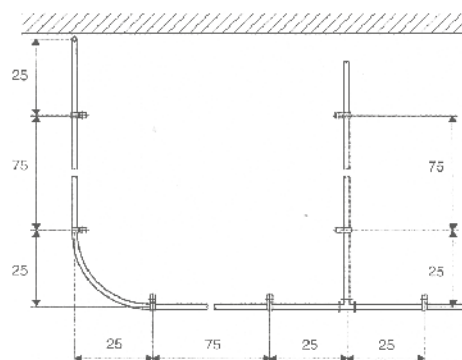

Multilayer FLUXO® Pipe

The FLUXO® pipe is produced through the combination of an aluminium alloy and high quality crosslinked polyethylene. The aluminium core provides a lower thermal linear expansion compared to other plastic materials that are generally used in heating and domestic plumbing systems. The external layer protects the aluminium from potential corrosion risks providing mechanical, electrical and chemical protection. Additionally, the internal layer is fully suited to be in contact with water, as certified by external laboratories. The multilayer FLUXO® pipe is produced and certified according to the UNI EN ISO 21003 standard.

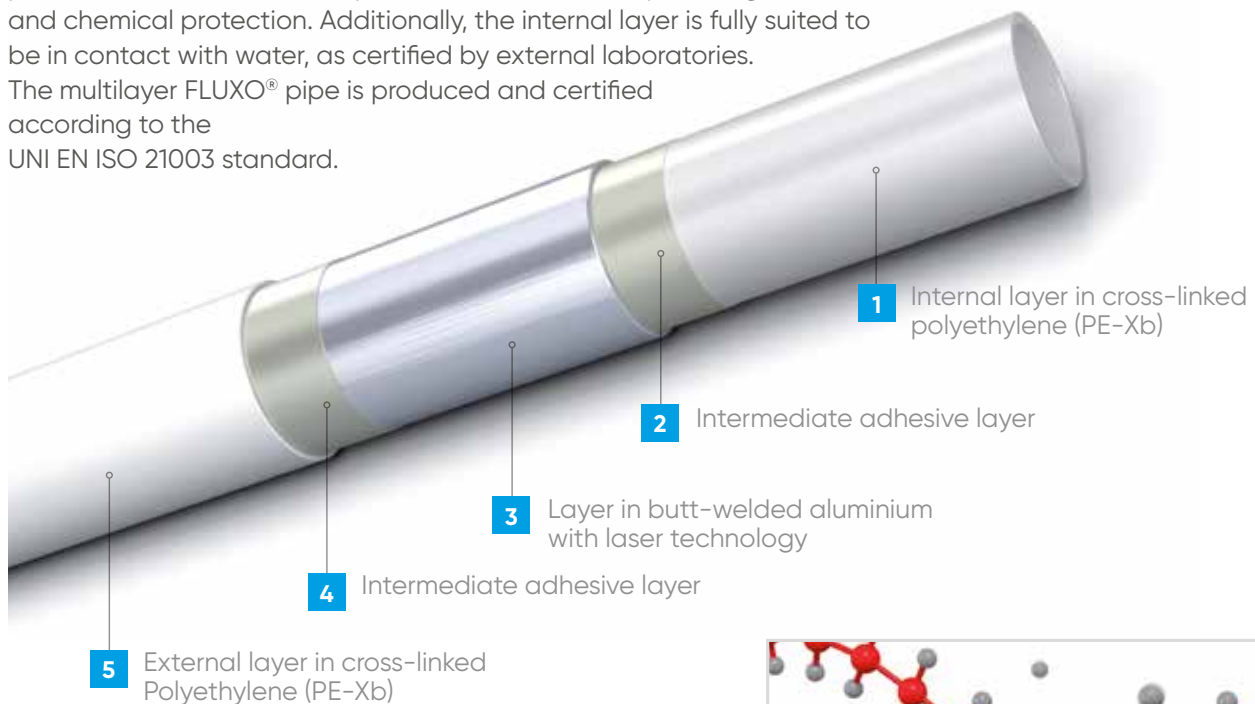

Inner aluminium core:

The butt-welded aluminium using 5 micron laser technology, can withstand the highest pressures. It creates an 100% impenetrable oxygen barrier and a UV-protection barrier, significantly preventing the formation of algae inside the system. Elastic memory makes the installation simple and reduces the use of pipe fittings.

Internal and external layer in cross-linked polyethylene (PE-Xb)

Exceptional temperature resistance Thanks to cross-linking, PEX is the most long-lasting and resistant plastic material to hot and cold water cycles under pressure. This makes the FLUXO® pipe perfect for the installation of heating and domestic water-supply systems.

Anti-corrosion The internal and external PEX layers ensure total protection of the aluminium layer inside.

Soundproofing The PEX layers absorb vibrations and sounds produced by water flows and water-hammer effects.

Drinking water The PEX layer is suitable for drinking water and food fluids.

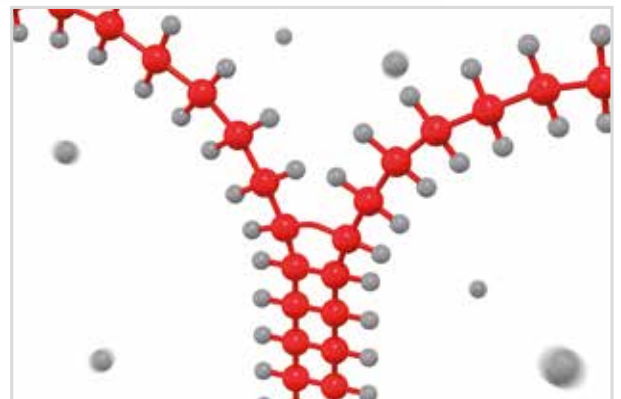

Cross-linked polyethylene (PE-Xb). Permanent link between the molecular chains thanks to crosslinking.

Insulation sheath



The multilayer Fluxo pipe is covered with a high-performance insulating sheath with the following **certified** features:

- White exterior
- Polyethylene closed-cell foam material (recyclable)
- Class 1 fire-resistance classification
- Density 35kg/m³
- Service temperature range -45°C + 100°C
- Permeability coefficient >6000
- Thermal conductivity coefficient at 40°C 0.039 W/(m*K)
- Non-toxic
- CFC (Freon) CFC-Free

Naked pipe in coils, packed in boxes

Tube multicouche nu en couronne, emballage en boîte de carton
Tubería multicapa en rollo, embalaje en caja de cartón





Ø (mm)	Thickness pipe (mm)	Reference	 (mt)	 (mt)	Coil (m)	Note
16	2.0	M010566	100	2.800	100	
20	2.0	M011535	100	1.800	100	
26	3.0	M012626	50	900	50	
32	3.0	M013208	50	450	50	

Insulated pipe in coils, packed in boxes

Tube multicouche pré-isolé en couronne, emballage en boîte de carton - Tubería multicapa preaislado en rollo, embalaje en caja de cartón





Ø (mm)	Thickness pipe (mm)	Insulation thickness (mm)	Reference	 (mt)	 (mt)	Coil (m)	Note
16	2.0	6	M040537	50	900	50	
20	2.0	6	M041528	50	900	50	
20	2.0	10	M041524	50	500	50	
26	3.0	10	M042617	50	500	50	
32	3.0	10	M043208	25	225	25	

"Polar" insulated pipe for cooling systems, packed in boxes (for systems with fancoil units, heat pumps)

Tube multicouche pré-isolé "Polar" en couronne, emballage en boîte de carton - Tubería multicapa preaislado "Polar" en rollo, embalaje en caja de cartón





Ø (mm)	Thickness pipe (mm)	Insulation thickness (mm)	Reference	 (mt)	 (mt)	Coil (m)	Note
16	2.0	10	MT116PT	50	900	50	
20	2.0	10	MT120PT	50	900	50	
26	3.0	10	MT126PT	50	900	50	
32	3.0	10	MT132PT	25	225	25	

With special sheath

Straight pipes

Tube multicouche nu en barre - Tubería multicapa en barra





Ø (mm)	Thickness pipe (mm)	Reference	 (mt)	 (mt)	mt	Pack (no. of bars)	Note
16	2.0	M020511	100	4.800	4	25	
20	2.0	M021514	64	3.072	4	16	
26	3.0	M022612	40	1.920	4	10	
32	3.0	M023208	28	1.344	4	7	
40	3.5	M023307	25	500	5	5	
50	4.0	M023407	25	500	5	5	
63	4.5	M023507	15	300	5	3	
75	5.0	M023602	10	200	5	2	



Naked pipe in coils, toroidal packaging



Tube multicouche nu en couronne
Tubería multicapa en rollo

Ø (mm)	Thickness pipe (mm)	Reference	 (mt)	 (mt)	Coil (m)	Note
16	2.0	M010520	100	2.000	100	
20	2.0	M011510	100	1.300	100	
26	3.0	M012610	50	600	50	
32	3.0	M013220	50	400	50	



White Pipe System in coils, toroidal packaging



Tube multicouche "System" pré-isolé en couronne, couleur blanche - Tubería multicapa "System" en rollo, color blanco

Ø (mm)	Thickness pipe (mm)	Insulation thickness (mm)	Reference	 (mt)	 (mt)	Coil (m)	Note
16	2.0	6	M040511	50	700	50	
20	2.0	6	M041513	50	700	50	
20	2.0	10	M041515	50	500	50	
26	3.0	10	M042605	50	400	50	
32	3.0	10	M043206	25	225	25	



Blue Pipe System in coils, toroidal packaging



Tube multicouche "System" pré-isolé en couronne, couleur bleue - Tubería multicapa "System" en rollo, color azul

Ø (mm)	Thickness pipe (mm)	Insulation thickness (mm)	Reference	 (mt)	 (mt)	Coil (m)	Note
16	2.0	6	M040505	50	700	50	
20	2.0	6	M041505	50	700	50	
26	3.0	10	M042604	50	400	50	
32	3.0	10	M043209	25	225	25	



Red Pipe System in coils, toroidal packaging

Tube multicouche "System" pré-isolé en couronne, couleur rouge - Tubería multicapa "System" en rollo, color rojo



Ø (mm)	Thickness pipe (mm)	Insulation thickness (mm)	Reference	 (mt)	 (mt)	Coil (m)	Note
16	2.0	6	M040516	50	700	50	
20	2.0	6	M041504	50	700	50	
26	3.0	10	M042603	50	400	50	
32	3.0	10	M043207	25	225	25	



Pipe "Tech" in coils, toroidal packaging

Tube multicouche "Tech" en couronne



Tubería multicapa "Tech" en rollo

Ø (mm)	Thickness pipe (mm)	Insulation thickness (mm)	Reference	 (mt)	 (mt)	Coil (m)	Note
16	2.0	13	M040514	50	400	50	
20	2.0	13	M041534	50	400	50	
26	3.0	13	M042600	50	350	50	
32	3.0	13	M043221	25	225	25	



Pipe corrugated blue in coils, packed in boxes



Tube multicouche pré-fourreauté bleu en couronne, emballage en boîte de carton - Tubería multicapa corrugada color azul, embalaje en caja de cartón

Ø (mm)	Thickness pipe (mm)	Reference	 (mt)	 (mt)	Coil (m)	Note
16	2.0	M060534	50	900	50	Corrugated blue
16	2.0	M060508	100	1.000	100	Corrugated blue
20	2.0	M061515	50	900	50	Corrugated blue



Pipe corrugated red in coils, packed in boxes

Tube multicouche pré-fourreauté rouge, emballage en boîte de carton - Tubería multicapa corrugada color rojo, embalaje en caja de cartón

Ø (mm)	Thickness pipe (mm)	Reference	 (mt)	 (mt)	Coil (m)	Note)
16	2.0	M060535	50	900	50	Corrugated red
16	2.0	M060509	100	1.000	100	Corrugated red
20	2.0	M061516	50	900	50	Corrugated red

Press Fittings

The press fittings of the FLUXO® range are designed to rapidly perform any type of installation with maximum flexibility and safety: the FLUXO® fittings are made in high-quality brass are in accordance with the ACS French health compliance standard.



1

Dielectric ring: avoids any contact with the aluminium of the pipe so as to eliminate any electrical conductivity risks

2

Inspection opening to check the pipe insertion

3

Double O-ring in EPDM perox

4

Stainless steel large sleeves. Stainless steel 304 used for the sleeves ensures high-resistance to corrosion and optimum pipe pressing.

The TH pressing system

We have chosen to use the TH pressing profile as it is the most widely used in the market. Furthermore, the TH profile gives more stability to the fitting inside the pressing jaws.

The pressing system for fittings between Ø 14 and Ø 63 is made using a TH version clamp which deforms the sleeve in solubilised stainless steel (AISI 304) creating the connection between the pipe and the fitting.

► *Fittings with diameters of 40 - 50 - 63 - 75 mm have a plastic sleeve-holder.*

Safety and health compliance

The brass alloys used to produce FLUXO® fittings, indicated as CW614N according to **UNI EN 12164** (for bar) and CW617N according to **UNI EN 12165** (for heat pressing), in terms of hygiene and drinking water, comply with the requirements provided **by the Italian Ministerial Decree 174 of 2004**.

Equipment:

If you already have a Rems, Rothenberger, Virax, Klauke or Novopress pressing machine and TH profile jaws, you can use the FLUXO® system with your equipment

If you have a pressing machine of one of the brands listed above but you do not have the TH profile jaws, all you need to do is replace the latter for use with FLUXO® fittings.

Bear in mind

- Simple installation
- Corrosion resistance
- System installation speed
- Health compliance certification
- Wide range to cover any installation requirement





Type A



Type B

Adapter male thread

Manchons à sertir, à visser mâles fixes

Racor prensado macho

Type	Ø Fitting	Ø Thread	Reference			Note
A	16	1/2"	MM1160P	10	6.000	
A	16	3/4"	MC1161P	10	7.290	
A	20	1/2"	MM1200P	10	6.000	
A	20	3/4"	MM1210P	10	7.000	
A	26	3/4"	MM1260P	10	4.860	
A	26	1"	MM1270P	10	4.860	
A	32	1"	MM1320P	5	3.645	
B	40	1" 1/4	MM1400P	5	1.200	▶ Plastic sleeve-holder
B	50	1" 1/2	MM1510P	2	972	▶ Plastic sleeve-holder
B	63	2"	MM1630P	2	972	▶ Plastic sleeve-holder
B	75	2" 1/2	MM1730P	1	8	▶ Plastic sleeve-holder



Type A



Type B

Adapter female thread

Manchons à sertir, à visser femelles fixes

Racor prensado hembra

Type	Ø Fitting	Ø Thread	Reference			Note
A	16	1/2"	MM4160P	10	6.000	
A	16	3/4"	MC1162P	10	8.000	
A	20	1/2"	MM4200P	10	6.000	
A	20	3/4"	MM4210P	10	7.290	
A	26	3/4"	MM4260P	10	4.860	
A	26	1"	MM4270P	10	800	
A	32	1"	MM4320P	5	3.645	
B	40	1" 1/4	MM4400P	5	810	▶ Plastic sleeve-holder
B	50	1" 1/2	MM4510P	2	1.458	▶ Plastic sleeve-holder
B	63	2"	MM4630P	2	240	▶ Plastic sleeve-holder
B	75	2" 1/2	MM4730P	1	8	▶ Plastic sleeve-holder





Type A



Type B



Straight coupler

Manchons à sertir égaux - Manguito prensado

Type	Ø Fitting	Reference			Note
A	16 x 16	MM2160P	10	6.000	
A	20 x 20	MM2200P	10	7.290	
A	26 x 26	MM2260P	10	4.860	
A	32 x 32	MM2320P	5	3.645	
B	40 x 40	MM2400P	5	810	▶ Plastic sleeve-holder
B	50 x 50	MM2500P	2	972	▶ Plastic sleeve-holder
B	63 x 63	MM2630P	2	128	▶ Plastic sleeve-holder
B	75 x 75	MM2750P	1	8	▶ Plastic sleeve-holder

Reducing coupling

Manchons à sertir réduits- Manguito reducido prensado

Type	Ø Fitting	Reference			Note
A	20 x 16	MM3210P	10	6.000	
A	26 x 16	MM3240P	10	4.860	
A	26 x 20	MM3260P	10	4.860	
A	32 x 20	MM3310P	5	800	
A	32 x 26	MM3320P	5	3.645	
B	40 x 26	MM3390P	5	400	▶ Plastic sleeve-holder
B	40 x 32	MM3400P	5	1.200	▶ Plastic sleeve-holder
B	50 x 26	MM3480P	2	240	▶ Plastic sleeve-holder
B	50 x 32	MM3490P	2	-	▶ Plastic sleeve-holder
B	50 x 40	MM3500P	2	972	▶ Plastic sleeve-holder
B	63 x 40	MM3620P	2	-	▶ Plastic sleeve-holder
B	63 x 50	MM3630P	2	972	▶ Plastic sleeve-holder
A	75 x 40	MM3640P	1	8	▶ Plastic sleeve-holder
A	75 x 50	MM3641P	1	-	▶ Plastic sleeve-holder
A	75 x 63	MM3642P	1	-	▶ Plastic sleeve-holder



Type A



Type B

Equal tee 90°

Tés à sertir égaux 90° - Te prensado 90°

Type	ØA x ØB x ØC Fitting	Reference			Note
A	16 x 16 x 16	MD1160P	10	4.860	
A	20 x 20 x 20	MD1200P	10	2.400	
A	26 x 26 x 26	MD1260P	10	1.620	
A	32 x 32 x 32	MD1320P	5	810	
B	40 x 40 x 40	MD1400P	5	-	▶ Plastic sleeve-holder
B	50 x 50 x 50	MD1500P	2	16	▶ Plastic sleeve-holder
B	63 x 63 x 63	MD1630P	2	162	▶ Plastic sleeve-holder
B	75 x 75 x 75	MM1631P	1	1	▶ Plastic sleeve-holder

Reducing tee 90°

Tés à sertir réduits 90° - Te reducida prensado 90°

Type	ØA x ØB x ØC Fitting	Reference			Note
A	20 x 16 x 20	MD3150P	10	2.400	
A	20 x 26 x 20	MD2200P	10	1.620	
A	26 x 16 x 26	MD3230P	10	1.620	
A	26 x 20 x 26	MD3270P	10	1.620	
A	26 x 32 x 26	MD2310P	5	400	
A	32 x 16 x 32	MD3320P	5	400	
A	32 x 20 x 32	MD3350P	5	810	
A	32 x 26 x 32	MD3370P	5	810	
A	32 x 40 x 32	MD1261P	5	320	
B	40 x 20 x 40	MD1262P	5	-	▶ Plastic sleeve-holder
B	40 x 26 x 40	MD3400P	5	360	▶ Plastic sleeve-holder
B	40 x 32 x 40	MD3410P	5	320	▶ Plastic sleeve-holder
B	50 x 26 x 50	MD3420P	2	16	▶ Plastic sleeve-holder
B	50 x 32 x 50	MD3430P	2	16	▶ Plastic sleeve-holder
B	50 x 40 x 50	MD3440P	2	128	▶ Plastic sleeve-holder
B	63 x 26 x 63	MD3450P	2	128	▶ Plastic sleeve-holder
B	63 x 32 x 63	MD3460P	2	128	▶ Plastic sleeve-holder
B	63 x 40 x 63	MD3470P	2	-	▶ Plastic sleeve-holder
B	63 x 50 x 63	MD3480P	2	-	▶ Plastic sleeve-holder
B	75 x 50 x 75	MM3481P	1	162	▶ Plastic sleeve-holder
B	75 x 63 x 75	MM3482P	1	8	▶ Plastic sleeve-holder

Unequal Reducing tee 90°

Tés à sertir réduits double 90° - Te reducida prensado 90°

Type	ØA x ØB x ØC Fitting	Reference			Note
A	16 x 20 x 16	MD2121P	10	1.200	
A	20 x 16 x 16	MD2140P	10	4.860	
A	20 x 20 x 16	MD2180P	10	2.400	
A	26 x 26 x 16	MD2280P	10	800	
A	26 x 16 x 20	MD2220P	10	1.620	
A	26 x 20 x 16	MD2250P	10	800	
A	26 x 26 x 20	MD2300P	10	800	
A	26 x 20 x 20	MD2122P	10	800	
A	32 x 20 x 26	MD2340P	5	-	
A	32 x 32 x 26	MD2380P	5	-	
A	32 x 26 x 26	MD2360P	5	810	
B	40 x 32 x 32	MD2124P	5	-	▶ Plastic sleeve-holder

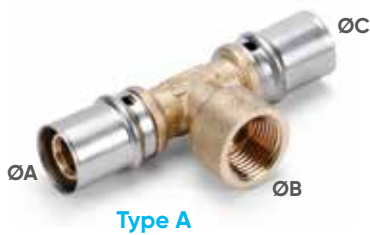

Type A



Type B

Tee 90° female thread

Tés à sertir, femelles à visser 90° - Te rosca hembra 90°

Type	$\varnothing A \times \varnothing B \times \varnothing C$ Fitting	Reference			Note
A	16 x 1/2" x 16	MD5160P	10	4.860	
A	20 x 1/2" x 20	MD5200P	10	2.400	
A	20 x 3/4" x 20	MD5210P	10	800	
A	26 x 3/4" x 26	MD5260P	10	1.620	
A	26 x 1" x 26	MD5142P	10	800	
A	32 x 1" x 32	MD5320P	5	810	
B	40 x 1" x 40	MD5143P	5	320	▶ Plastic sleeve-holder
B	40 x 1 1/4 x 40	MD5400P	5	360	▶ Plastic sleeve-holder
B	50 x 1 1/2 x 50	MD5500P	2	324	▶ Plastic sleeve-holder
B	50 x 3/4" x 50	MD5144P	2	128	▶ Plastic sleeve-holder
B	50 x 1" x 50	MD5145P	15	120	▶ Plastic sleeve-holder
B	63 x 1" x 63	MD5630P	2	128	▶ Plastic sleeve-holder
B	63 x 2" x 63	MD5640P	2	128	▶ Plastic sleeve-holder



Type A

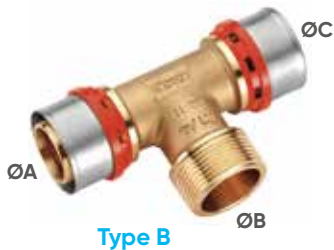

Type B

Tee 90° male thread

Tés à sertir, mâles à visser 90° - Te rosca macho 90°

Type	$\varnothing A \times \varnothing B \times \varnothing C$ Fitting	Reference			Note
A	16 x 1/2" x 16	MD4160P	10	4.860	
A	20 x 1/2" x 20	MD4200P	10	-	
A	20 x 3/4" x 20	MD4210P	10	-	
A	26 x 3/4" x 26	MD4260P	10	800	
A	26 x 1" x 26	MD4161P	10	800	
A	32 x 1" x 32	MD4320P	5	-	
B	40 x 1 1/4" x 40	MD4400P	5	-	▶ Plastic sleeve-holder
B	50 x 1 1/2" x 50	MD4500P	2	-	▶ Plastic sleeve-holder
B	63 x 2" x 63	MD4630P	2	128	▶ Plastic sleeve-holder

Elbow female thread

Coudes à sertir, femelles à visser - Codo rosca hembra



Type A

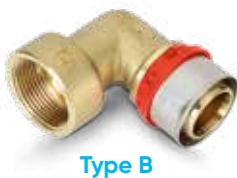

Type B

Type	\varnothing Fitting	\varnothing Thread	Reference			Note
A	16	1/2"	MC3160P	10	7.290	
A	16	3/4"	MC3131P	10	1.600	
A	20	1/2"	MC3200P	10	7.290	
A	20	3/4"	MC3210P	10	4.860	
A	26	3/4"	MC3260P	10	2.400	
A	26	1"	MC3133P	10	800	
A	32	1"	MC3320P	5	2.430	
B	40	1" 1/4	MC3400P	5	320	▶ Plastic sleeve-holder
B	50	1" 1/2	MC3510P	2	480	▶ Plastic sleeve-holder
B	63	2"	MC3630P	2	128	▶ Plastic sleeve-holder

Elbow male thread**Coudes à sertir, mâles à visser - Codo rosca macho**

Type A



Type B

Type	Ø Fitting	Ø Thread	Reference			Note
A	16	1/2"	MC2160P	10	7.290	
A	16	3/4"	MC2201P	10	1.600	
A	20	1/2"	MC2200P	10	7.290	
A	20	3/4"	MC2210P	10	4.860	
A	26	3/4"	MC2260P	10	2.400	
A	26	1"	MC2203P	10	800	
A	32	1"	MC2320P	5	2.430	
B	40	1" 1/4	MC2400P	5	-	▶ Plastic sleeve-holder
B	50	1" 1/2	MC2510P	2	-	▶ Plastic sleeve-holder
B	63	2"	MC2630P	2	128	▶ Plastic sleeve-holder

Elbow 90°**Coudes à sertir à 90° - Codo 90°**

Type A



Type B

Type	Ø Fitting	Reference			Note
A	16 x 16	MC1160P	10	7.290	
A	20 x 20	MC1200P	10	4.860	
A	26 x 26	MC1260P	10	2.400	
A	32 x 32	MC1320P	5	2.430	
B	40 x 40	MC1400P	5	360	▶ Plastic sleeve-holder
B	50 x 50	MC1500P	2	324	▶ Plastic sleeve-holder
B	63 x 63	MC1630P	2	324	▶ Plastic sleeve-holder
A	75 x 75	MC1650P	1	8	▶ Plastic sleeve-holder

Elbow 45°**Coudes à sertir à 45° - Codo 45°**

Size	Reference			Note
40 x 40	MG1140P	5	-	
50 x 50	MG1160P	2	-	
63 x 63	MG1200P	2	324	
75 x 75	MG1210P	1	32	



Wall-threaded-bracket female elbow

Coudes appliques à sertir, femelles à visser

Codo fijación rosca hembra

Ø Fitting	Ø Thread	Reference	Length (mm)			Note
16	1/2"	MF3160P	53	10	2.400	
20	1/2"	MF3200P	53	10	2.400	



Long Wall-Threaded-Bracket Female Elbow

Coudes appliques à sertir, femelle à visser hauteur

Codo fijación largo rosca hembra

Ø Fitting	Ø Thread	Reference	Length (mm)			Note
16	1/2"	MF5160P	81	10	800	Long version
20	1/2"	MF3182P	81	10	800	Long version



Double wall-threaded-bracket female elbow

Coudes appliques double à sertir, femelles à visser

Codo fijación doble rosca hembra

Ø Fitting	Ø Thread	Reference			Note
16 x 16	1/2"	MF3138P	10	800	
20 x 20	1/2"	MF3184P	10	800	



Swivel adaptor for manifolds

Manchons à sertir, à visser écrous tournants siège plat

Manguito tuerca loca

Ø Fitting	Ø Thread	Reference			Note
16	1/2"	MM4131P	5	480	
20	1/2"	MM4132P	10	6.000	
20	3/4"	MM4133P	10	7.290	
26	3/4"	MM4134P	5	400	
26	1"	MM4135P	5	400	
32	1"	MM4136P	5	400	
32	1" 1/4	MM4137P	5	400	
40	1" 1/4	MM4138P	5	400	
50	1" 1/2	MM4139P	2	160	
63	2"	MM4140P	2	128	
75	2" 1/2	MM4141P	1	8	



Adaptor for copper

Manchons à sertir, de transition FLUXO® cuivre
Manguito de transición para cobre

Ø Fitting	Reference			Note
16 MLP X 14 COPPER	MM5135P	10	800	
16 MLP X 16 COPPER	MM5136P	10	800	
20 MLP X 22 COPPER	MM5138P	10	800	



Sleeve stainless steel

Bague de sertissage laiton inox
Injerto acero inoxidable

Ø x Thickness (mm)	Reference			Note
16 x 2.0	MB1160P	10	80	
20 x 2.0	MB1200P	10	80	
26 x 3.0	MB1260P	10	800	
32 x 3.0	MB1320P	10	80	
40 x 3.5	MB1400P	5	40	
50 x 4.0	MB1500P	5	40	
63 x 4.5	MB1630P	2	16	
75 x 5.0	MB1750P	1	8	



In-wall ball valve (Chrome Cover Included)

Robinet avec cartouche à encastrer
Válvula de esfera para empotrar

Ø Fitting	Reference			Note
16 x 16	MV1160P	4	-	
20 x 20	MV1200P	4	-	



Extension kit for in wall ball valve

Jeu rallonge pour robinet - Alargadera grifo

Reference			Note
MPR010P	1	-	



Chromed cover for in wall ball valve

Capuchon et rosette pour robinets encastrés
Plafón embellecedor cromado

Reference			Note
MCA010P	4	-	



Threaded Manifolds Adapter

Raccords à compression pour collecteur

Adaptador para colectores

Ø Pipe	Ø Thread	Reference			Note
16 x 2.0	1/2"	MA1160P	2	12.000	
16 x 2.0	3/4"	MA1170P	10	2.000	
20 x 2.0	3/4"	MA1210P	10	-	

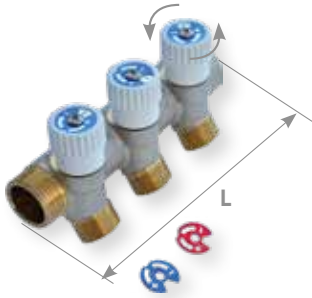

Manifold with stop valves

Collecteurs de distribution avec robinet d'arrêt

Colceter de distribución con válvulas de cierre

Ways	Ø Inlet	Ø Outlets	Reference			L (mm)	Spacing (mm)	Note
2	3/4"	1/2"	MA3172C	6	1.440	98	40	
2	1"	1/2"	MA3162C	1	96	98	40	
3	3/4"	1/2"	MA3173C	1	80	138	40	
3	1"	1/2"	MA3163C	2	324	138	40	
4	3/4"	1/2"	MA3174C	4	960	178	40	
4	1"	1/2"	MA3164C	2	324	178	40	



End cap for manifolds

Bouchons pour collecteurs - Tapón final para colectores

Ø Threads	Type of thread	Reference			Note
3/4"	Male	MT1340C	1	-	
1"	Male	MT1100C	1	-	
1/2"	Female	MT2120C	1	-	
3/4"	Female	MT2340C	1	-	
1"	Female	MT2100C	1	-	

Multilayer accessories

Internal pipe-bending spring

Ressorts de cintrage intérieurs - Muelle de flexión interior



Ø (mm)	Reference			Thickness	Note
16	MMC160A	1	8	2.0	
20	MMC200A	1	8	2.0	
26	MMC260A	1	8	2.0	

Pipe calibrator

Calibreur chanfreineur manuel à poignée 4 diamètres

Calibrador de tubo



Ø (mm)	Reference			Note
14 - 16 - 18 - 20	MCT200A	1	-	
20 - 26 - 32 - 40	MCT400A	1	-	



Countersink calibrator Calibreur chanfreineur - Calibrador achaflanador

Ø (mm)	Reference			Note
50	MSB200A	1	8	
63	MSB400A	1	8	

Pipe cutter shears Coupe-tube multicouche - Cizalla cortatubo



Ø (mm)	Reference			Note
from 14 to 26	MCT260A	100	800	

Pipe cutter Coupe tube automatique Avec ébavureur interne rétractable Cortador de tubo



Ø (mm)	Reference			Note
from 10 to 40	MS1600C	1	8	
from 50 to 110	MS1610C	1	8	

Bending KIT 16-18-20-25/26-32 Swing 16-18-20-25/26-32 cintreuse arbalète set multicouche Set doblador de ballesta para tubo multicapa 16-18-20-25/26-32



Reference			Note
MMC132A	1	8	



Battery-powered pressing machine "Rems" (without jaws) Sertisseuse sur batterie (sans pince) Engarzadora a batería (sin mordaza)



Model	Ø (mm)	Reference			Note
AKKU-PRESS ACC	10-108	MK3260A	1	8	With automatic return
AKKU-PRESS	10-108	MK3PBOA	1	8	



Electric pressing machine "Rems" (without jaws)
Sertisseuse filaire (sans pince)
Engarzadora eléctrica (sin mordaza)

Model	∅ (mm)	Reference			Note
POWER-PRESS 2000*	10-108	MK2260A	1	8	
POWER-PRESS E	10-108	MK2PE0A	1	8	

* Electrical limit switch

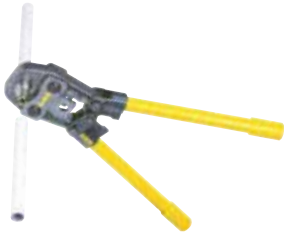



Manual pressing machine "Rems" (without jaws)
Sertisseuses manuel
Engarzadora manual (sin mordaza)

Model	∅ (mm)	Reference			Note
ECO-PRESS	10-26	MK2100A	1	8	



Pressing jaw
Pinces à sertir pour sertisseuses universelles
Mordaza para engarzadora universal

∅ (mm)	Reference			Note
TH 16	MG1160A	1	8	
TH 20	MG1200A	1	8	
TH 26	MG1260A	1	8	
TH 32	MG1320A	1	8	
TH 40	MG1400A	1	8	
TH 50	MG1500A	1	8	
TH 63	MG1630A	1	8	
INTERMEDIATE CLAMP TH 75	MG1750A	1	8	
PRESS RING TH 75	MG1751A	1	8	